



SHENZHEN POLINOVEL TECHNOLOGY CO., LTD

V Series Solar Home Battery

(Lithium-Iron Phosphate Battery)

Product Manual

Version: 2.0

SHENZHEN POLINOVEL TECHNOLOGY CO., LTD

1010 Longnian Building, 29 Longcheng Avenue, Nanlian Block, Longgang Str.,
Longgang District, Shenzhen, 518100, China

Tel: (86)755-28906569

Fax: (86)755-28903442

Email: sales@polinovel.com

Web: www.polinovel.com

LEGAL NOTICES

Copyright of Shenzhen Polinovel Technology Co., Ltd. Enjoin from abstracted reproduced or translated by any unit or individual in any way without the written permission.

Rights Reserved.

This product confirms to environmental protection and personal security. Product storage, using and disposal should be in accordance with product manuals, relevant contract and national laws.

When required product updates or technical changes, you can visit website of Polinovel (www.polinovel.com) for the latest information, without notice if the product improvements or technical change in other way.

Information Version: V2.0

Information Number: MKT-EX218-11

Revise History

Revision NO.	Revision Date	Revision Reason
1.0	2018.11.20	First Release
2.0	2020.5.8	Revision on parameter

Preface

Thank you for using the Wall-Mounted Solar Home Battery from Shenzhen Polinovel Technology Co., Ltd.

In order to bring you the best product at the best price under the safest conditions, we have been making progress all the time. Because of your concern, our efforts will be verified.

This manual describes the use of our Wall-Mounted Solar Home Battery, including functions and features, performance indicators, outline structure, and operating modes. Meanwhile, installation instructions, use and operation, maintenance management, transportation and storage are also listed in details.

Notes:

The input voltage and output voltage of the battery are all above 48V DC. **The improper operation will cause short circuit or damage to load devices.** Please read this manual carefully before installation and operation, pay attention to the various signs on the device, and do not let children touch it alone to prevent accidents. Do not remove the battery case from non-professional maintenance personnel.

Contents

1	Safety Instructions.....	5
1.1	Symbol Description.....	5
1.2	Precautions.....	5
2	Product Introduction.....	7
2.1	Product Description.....	7
2.2	Product Features.....	8
2.3	Product Model.....	8
2.4	Battery Management System (BMS).....	8
2.5	Charge Parameters.....	10
2.6	Discharge Parameters.....	10
2.7	Installation.....	11
2.8	Transportation.....	11
2.9	Storage.....	11
3	Installation Instructions.....	13
3.1	Installation requirements.....	13
3.2	Battery pack appearance and structure.....	14
3.3	Handling and Installation.....	14
3.4	Panel and Switch Button Description.....	18
3.5	Sleep Mode.....	19
3.6	Parallel Use.....	20
3.7	Troubleshooting.....	22

1 Safety Instructions

This chapter describes safety signs and safety precautions. Please read this chapter carefully before proceeding with any operation on this product to avoid personal safety or equipment damage due to unsafe operation.

1.1 Symbol Description

The safety symbols referenced in this manual are shown in Figure 1.1-1. These symbols are used to remind the user of the safety precautions that should be followed when installing, operating, and maintaining the product.

Symbol	Description
	be careful
	Beware of electric shock
	AC
	DC
	Ground protection
	Repeated loop
	keep clean

Figure 1.1-1

1.2 Precautions

During the installation, operation and maintenance of the product, the relevant safety regulations and relevant operating procedures must be observed, otherwise personal safety and equipment damage may be endangered. The safety precautions mentioned in the manual are only used as a supplement to local safety regulations.

The company does not assume any responsibility for breach of general safety operation requirements or violation of safety standards for design, production and use of product.



Battery use precautions

The Wall-Mounted Solar Home Battery is composed of a battery pack and a control system. Non-professionals and improper operation and use may cause serious consequences such as sparking and short circuit. The installation and maintenance of the system must be performed by professional technicians, and the use must strictly comply with the relevant safety regulations. Non-professionals are strictly prohibited from installing, repairing, and over-discriminating lithium battery packs.

1. Please read this manual and keep it in a safe place.
2. Please pay attention to all warning signs on the battery, do not tear or damage the warning labels.
3. Do NOT immerse the battery in sea water or water. When it is not in use, keep it in a cool and dry place.
4. Do NOT use or leave the battery near hot high temperature source, such as fire, heater, etc. Do NOT expose the lithium battery to fire, the lithium battery may explode.
5. Please charge it with the special charger for lithium battery. Do NOT plug the battery directly into the power socket.
6. Do NOT directly connect positive and negative terminals of the battery with metal.
7. Do NOT knock or throw the battery, step on the battery or directly solder the battery and pierce the battery with nails or other sharp objects.



Precautions

- Do not use or place the battery at high temperature, as this may cause the battery to overheat, ignite or fail, and shorten its life.
- Do not use in places with strong static electricity and strong magnetic field, otherwise it will easily damage the battery safety protection device and bring unsafe hidden dangers.
- If the battery leaks, the electrolyte enters the eyes, please do not rub it, rinse your eyes with clean water, and immediately send to medical treatment, otherwise it will hurt your eyes.
- If the battery emits an odor, get heat, discoloration or deformation, or any abnormality during use, storage, or charging, immediately remove the battery from the device or charger and stop using it.
- If the electrode is dirty, wipe it off with a dry cloth before use. Failure to do so may result in poor contact failure.
- Cover the electrode with insulating paper before discard the battery, to prevent fire caused by accidental short-circuit.



Keep the product well ventilated.

2 Product Introduction

2.1 Product Description

a. Polinovel wall-mounted solar home battery is an energy storage battery pack, which is used together with solar modules, solar inverters and power grid to form a residential energy storage system with off-grid function.

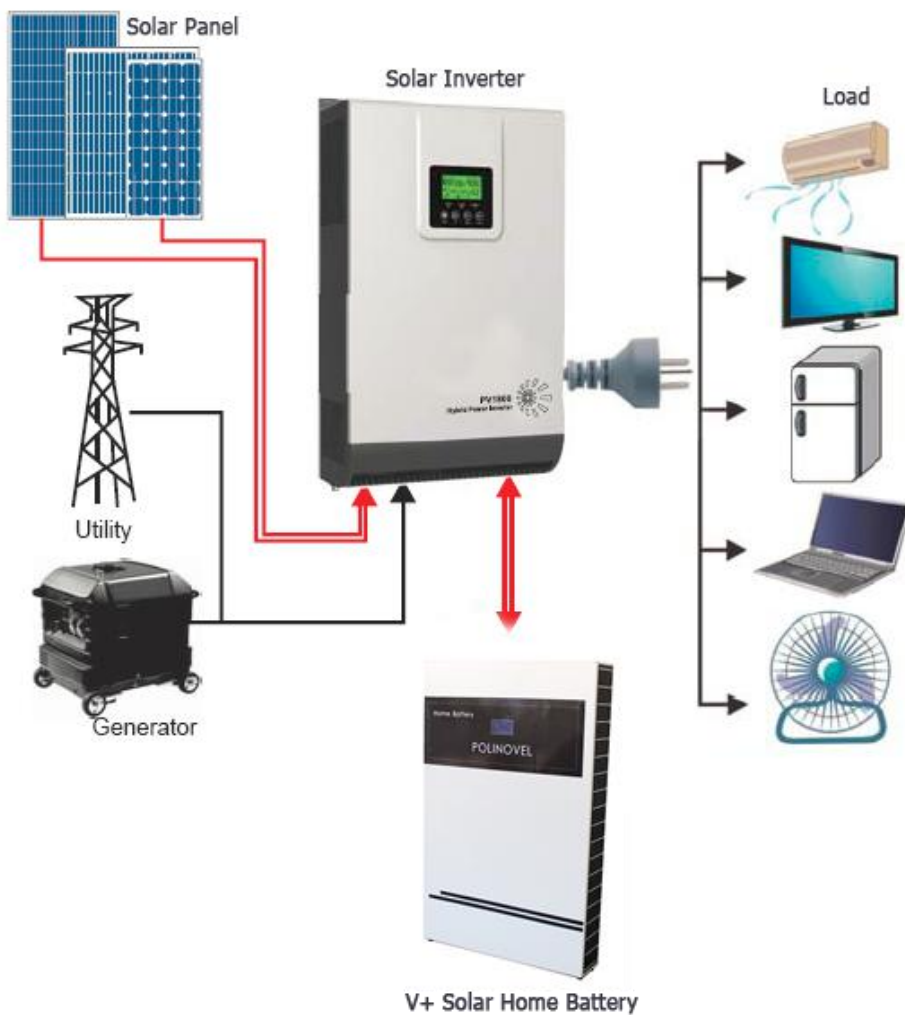

b. The energy storage battery pack serves as an energy storage unit, and constitutes a small micro grid system with power grid, solar modules, and solar inverter. The energy storage battery pack is a core component of the system.

2.2 Product Features

- (1) Display for checking battery status and operation, including,
 - a, battery SOC;
 - b, battery voltage and current;
 - C, battery charging and discharging status.



Figure 2-1

- (2) Battery management system and battery protection system.
- (3) English display.
- (4) Adopt lithium iron phosphate battery, safe and environmentally friendly.
- (5) Waterproof and dust-proof: IP65

2.3 Product Model

Table 2-1 V Series Solar Home Battery Model

Product Series	Model	Rated Voltage	Rated Capacity	Size	Net Weight
V Series	V3000	51.2V	60Ah	740x600x122mm	40kg
V Series	V3000H	51.2V	72Ah	740x600x122mm	45kg
V Series	V5000	51.2V	102Ah	938.5x605x122mm	73kg
V Series	V7000	51.2V	138Ah	1235x605x122mm	90kg
V Series	V8000	51.2V	162Ah	1235x605x122mm	100kg

2.4 Battery Management System (BMS)

2.4.1 Voltage Protection

Low Voltage Protection in Discharge

When discharging, the protection will turn on if the battery or any single cell has lower voltage, and the battery will stop discharging. When battery voltage or all single cells voltage are back to normal, protection will be removed.

High Voltage Protection in Charge

When charging, the protection will turn on if the battery or any single cell has high voltage, and the battery will stop charging. When battery voltage and all single cells voltage are back to normal, protection will be removed.

Voltage protection parameters please see "Table 2-2 Protection Parameters".

2.4.2 Current Protection

Over-current Protection in Charge

If the charging current is higher than the protection value, the battery will stop charging. As current back to normal, protection will be removed after the delay time.

Over-current Protection in Discharge

When the discharge current is higher than the protection value, the battery will stop discharging. Protection will be removed after the delay time. Protection parameters please see "Table 2-2 Protection Parameters".

Charging/Discharging Current Limit

To ensure the load product working safety, V Series solar home battery sets the maximum charge/discharge current protection values. Please see "Table 2-2 Protection Parameters".

In product working, the maximum operating current of electrical load should be less than the maximum battery discharge current.

2.4.3 Temperature Protection

Charging/Discharging Temperature Protection

Operation temperature of battery is 65°C, when temperature is above 65°C, protection will turn on and cut off power.

2.4.4 Additional Protection Features

Short Circuit Protection

If short circuit occurs, the system starts short circuit protection and cut off power lasts 30 seconds.

The protection parameters of V series solar home batteries please read table below.

Table 2-2 Protection Parameters

Item	Type	Protective Function	Parameter to Protection	Parameter to Remove Protection
1	Voltage	Cell Under-voltage in Discharging	2.5V	2.9V
2		Cell Over-voltage in Charging	3.75V	3.34V
3		Pack Under-voltage in Discharging	43.2V	51.2V
4		Pack Over-voltage in Charging	57.6V	54.6V
5	Current	Over-current in Charging	150A/1s	4 Seconds Delay
6		Over-current in Discharging	150A/1s	5 Seconds Delay
7	Temperature	Over Temperature	65°C	50°C

2.5 Charge Parameters

When the product working, reasonable charge voltage you should set, recommended charge voltage range shown in Table 2-3. The V series battery limits the maximum charge current to protect the power supply and load equipment.

Table 2-3 Charging Parameters

Model	Voltage Range in Charging		Current Limit in Charging	Recommend Current in Charging
	Min	Max	Max	
V3000	56V	57.6V	100A	≅ 60A
V3000H	56V	57.6V	100A	≅ 60A
V5000	56V	57.6V	100A	≅ 60A
V7000	56V	57.6V	100A	≅ 60A
V8000	56V	57.6V	100A	≅ 60A

2.6 Discharge Parameters

To protect the load equipment, V series battery limits the maximum discharge current shown in Table 2-4 below.

Table 2-4 Discharging Parameters

Model	Voltage Range in Discharging		Current Limit in Discharging
	Min	Max	Max
V3000	43.2V	57.6V	100A
V3000H	43.2V	57.6V	100A
V5000	43.2V	57.6V	100A
V7000	43.2V	57.6V	100A
V8000	43.2V	57.6V	100A

2.7 Installation

1. Please read this manual carefully before installation. If the product is not installed according to the instructions in this manual, or if the precautions and instructions in this manual are ignored, the company has the right to not provide warranty for the damages caused by this.

2. All operations and wiring, should be operated by professional electricians or mechanical engineers.

3. When installing, except for the terminal block and the part that must be removed, please do not move the other parts inside the box.

4. All electrical installations must comply with local electrical safety standards.

5. For maintenance, please contact the local designated system installation and maintenance personnel.

6. During the operation of the product, the temperature on the product may be relatively high. Please touch carefully to prevent burns.

2.8 Transportation

This solar home battery has undergone rigorous inspection and testing before leaving the factory. In order to avoid the battery pack from being damaged during transportation, please use soft materials such as EPE foam for packaging and transport in a customized wooden box. When transporting in non-container vehicles, the battery pack should be fixed as much as possible to ensure safe transportation.

2.9 Storage

1. This solar home battery is better to be well packed and stored in a ventilated and dry place;

2. The recommended storage temperature range is 5-45°C, humidity 65±20%;

3. If there are a large number of battery packs stored in the same place, the warehouse should meet following conditions,

a, the temperature and humidity in warehouse could be controlled, such as, there is air conditioning or dehumidification equipment, to avoid the battery pack in a high humidity environment for long time;

b, the warehouse should be equipped with automatic fire extinguishing system, emergency sprinkler system, dry powder fire extinguisher and fire sand (sand for construction is ok);

c, can not be mixed with flammable materials (such as packaging materials cartons, etc.), it is recommended to use a separate warehouse to store battery packs;

d, there' s secondary fire doors in the warehouse;

e. according to the instructions on the packaging of lithium battery and the stacking requirements, please do not stack more than a certain height;

4. For long time storage, the battery should be charged and discharged in time within 3 months to prevent it from being over-discharged; please do not store the battery for a long time if it is discharged.

3 Installation Instructions

3.1 Installation requirements

This part of the guide provides the installer with the choice of the appropriate installation location to avoid damage to the battery or the associated operator.

A. The product can be installed on the wall or on the ground.

To install it on the wall, the wall must be strong enough to bear the weight of the battery for a long time.

To install it on the ground, because the battery is tall and slim, it is also recommended to be fixed by the wall. Please refer to Chapter 3.3 for the installation method.

B. The installation location must conform to the size of the battery pack. Please refer to Figure 3-5 for dimensions.

C. Do not install the battery pack on the surface of a building constructed of flammable or non-heat resistant materials.

D. Do not install the battery pack in a place with poor air circulation to affect the natural heat dissipation of the battery pack.

E. The protection level of the battery pack is IP65. It can be installed indoors or outdoors. It is recommended not to expose the battery pack directly to the sun.

F. The ambient temperature around the battery pack should be -20~60°C.

G. Please pay attention to have enough clearance between the battery pack and other devices (recommend to be minimum 200 mm).

H. Do not install the battery pack in a place where children can reach it.

3.2 Battery pack appearance and structure

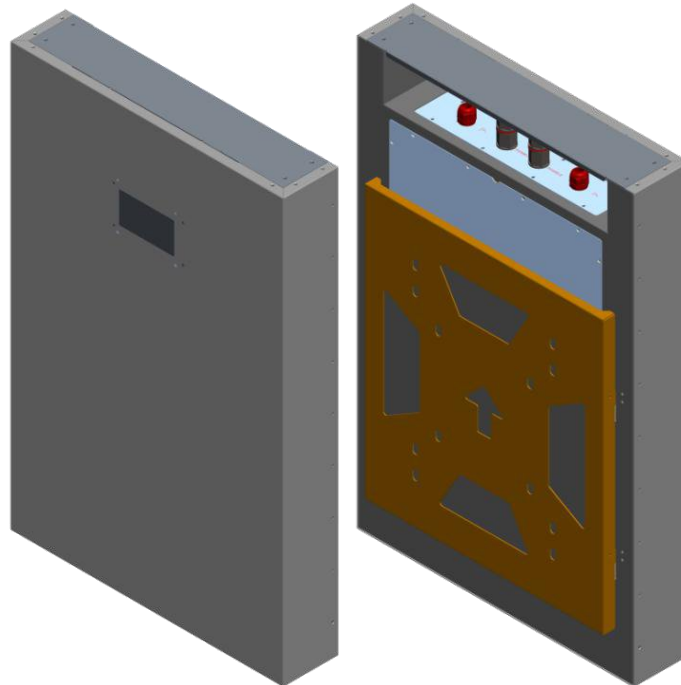

Figure 3-1

3.3 Handling and Installation

DANGER! The energy storage battery pack is heavy, pay attention to balance when handling, so as to prevent the battery from falling and hurting the operator.

Handling

Lift the battery out of the wooden box and move it to the designated installation location.

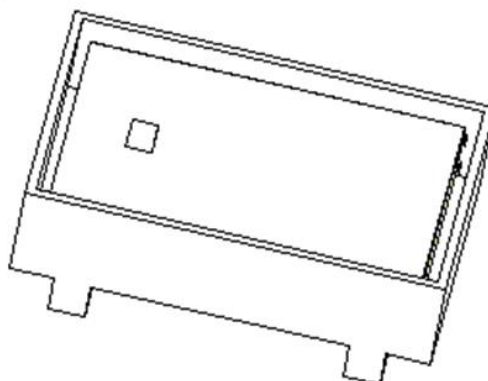

Figure 3-2

Installation Steps

(1) Install the wall mounting kits

a. Mark the drilling position on the wall with the wall mounting kits;

Figure 3-3 to Figure 3-5 show the outline of the battery pack and the shape of the wall mounting plate and the mounting hole size for all three models. Please check which model you ordered and take the correct drawing for reference.

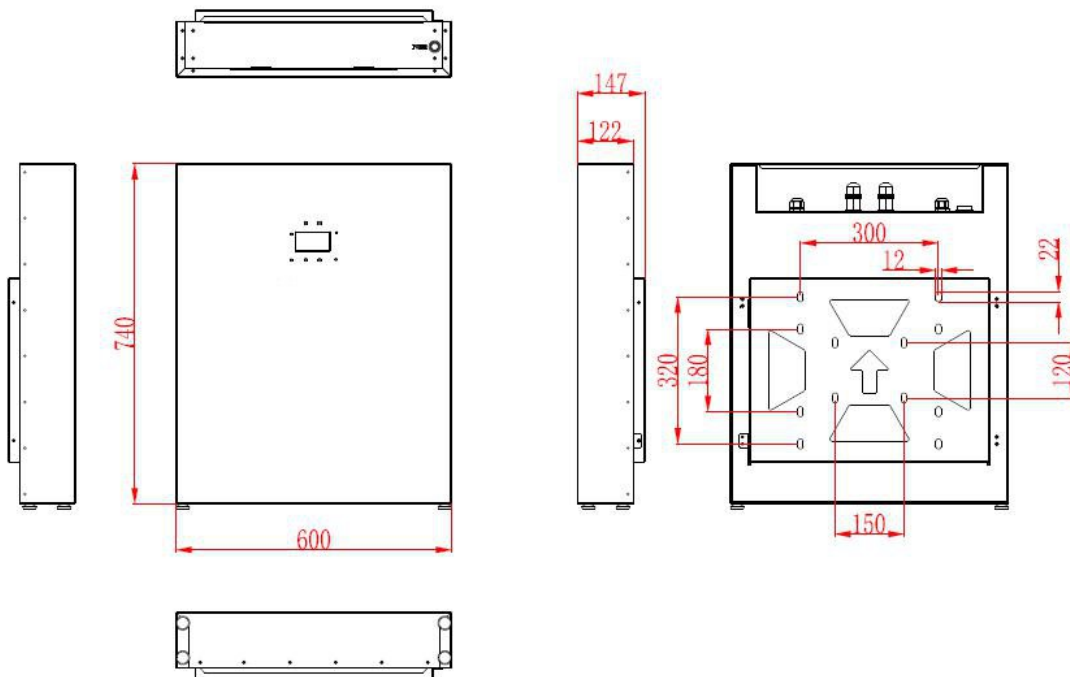

Figure 3-3 (Model V3000/V3000H)

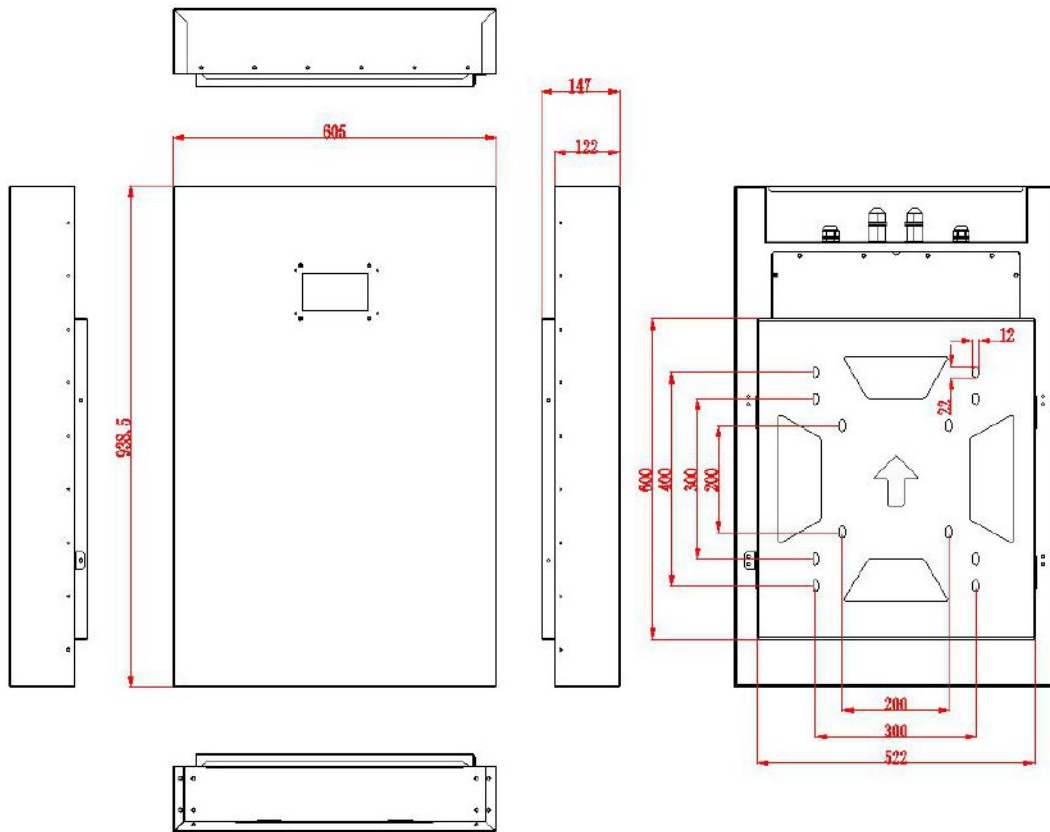

Figure 3-4 (Model V5000)

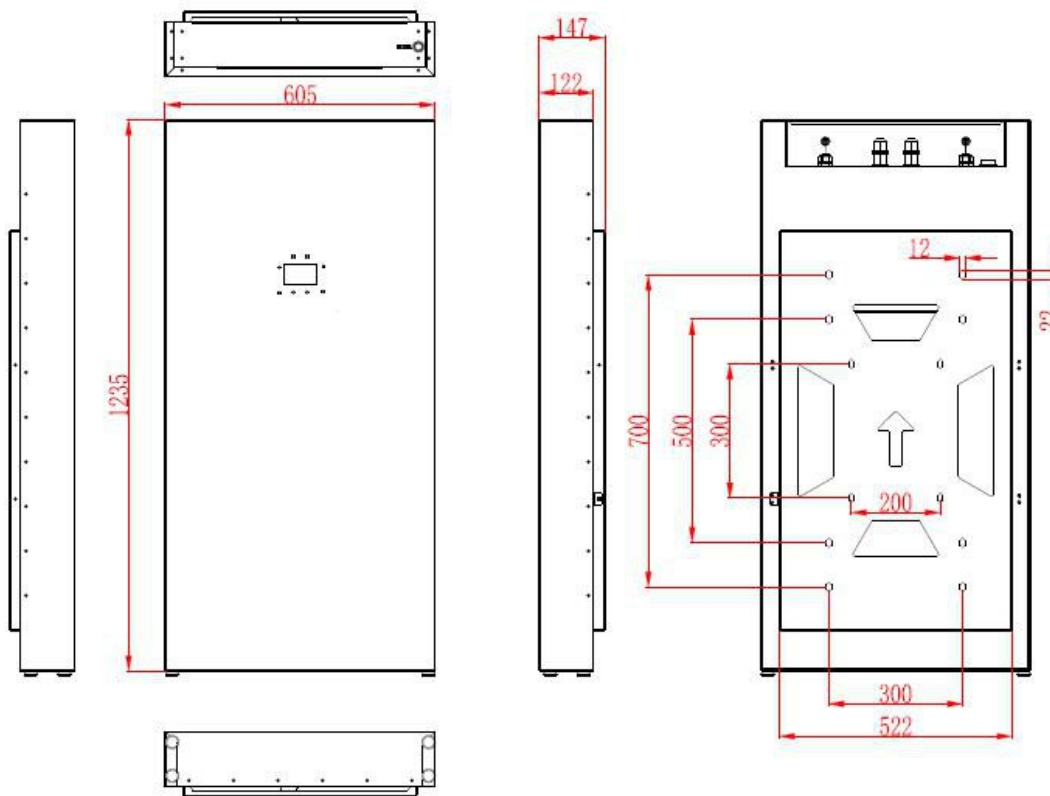

Figure 3-5 (Model V7000/V8000)

b. Drill holes in the marked positions with a hammer drill, insert the plastic parts, meanwhile, drill the tapping screws;

c. Install the wall mounting plate on the wall as shown in Figure 3-6 below; fix it with M8*50 tapping screws.

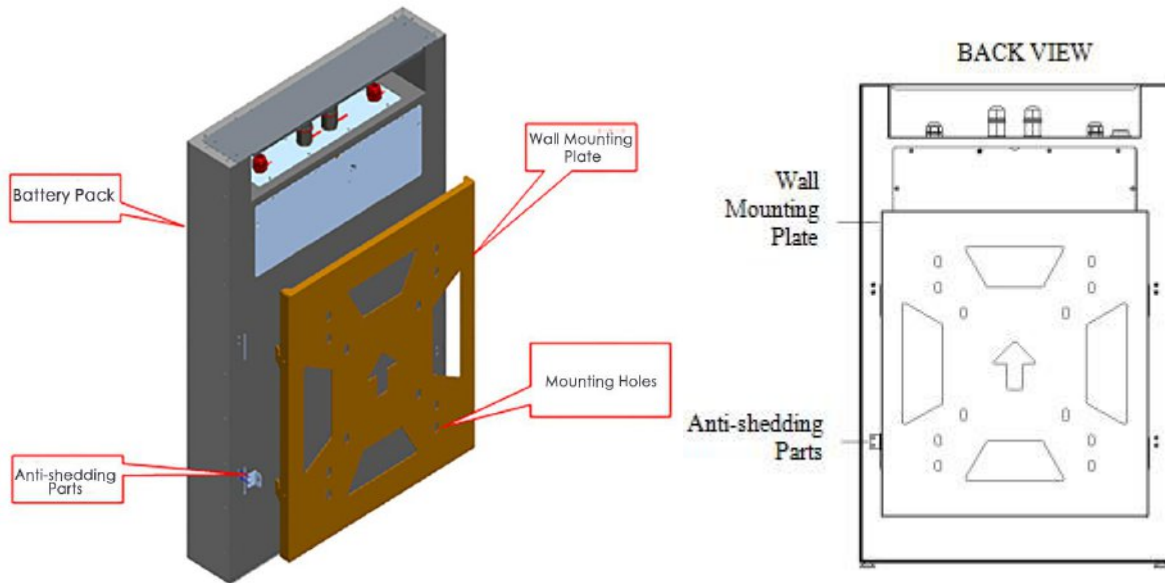

Figure 3-6

(2) Lift the battery pack and hook it on the wall mounting plate through the hooks on the wall mounting plate, as shown in Figure 3-7.

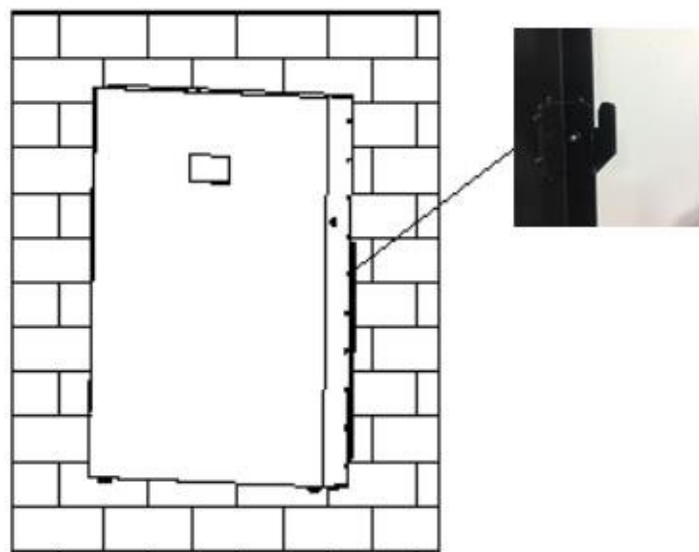

Figure 3-7

(4) Wire lug processing

This battery pack comes with two pieces of wire lugs, but does not come with the external positive and negative wire harness. When the battery pack is installed, the wire lug should be processed with proper wires (4AWG wires) as shown in Figure 3-8 below.



Figure 3-8

3.4 Panel and Switch Button Description

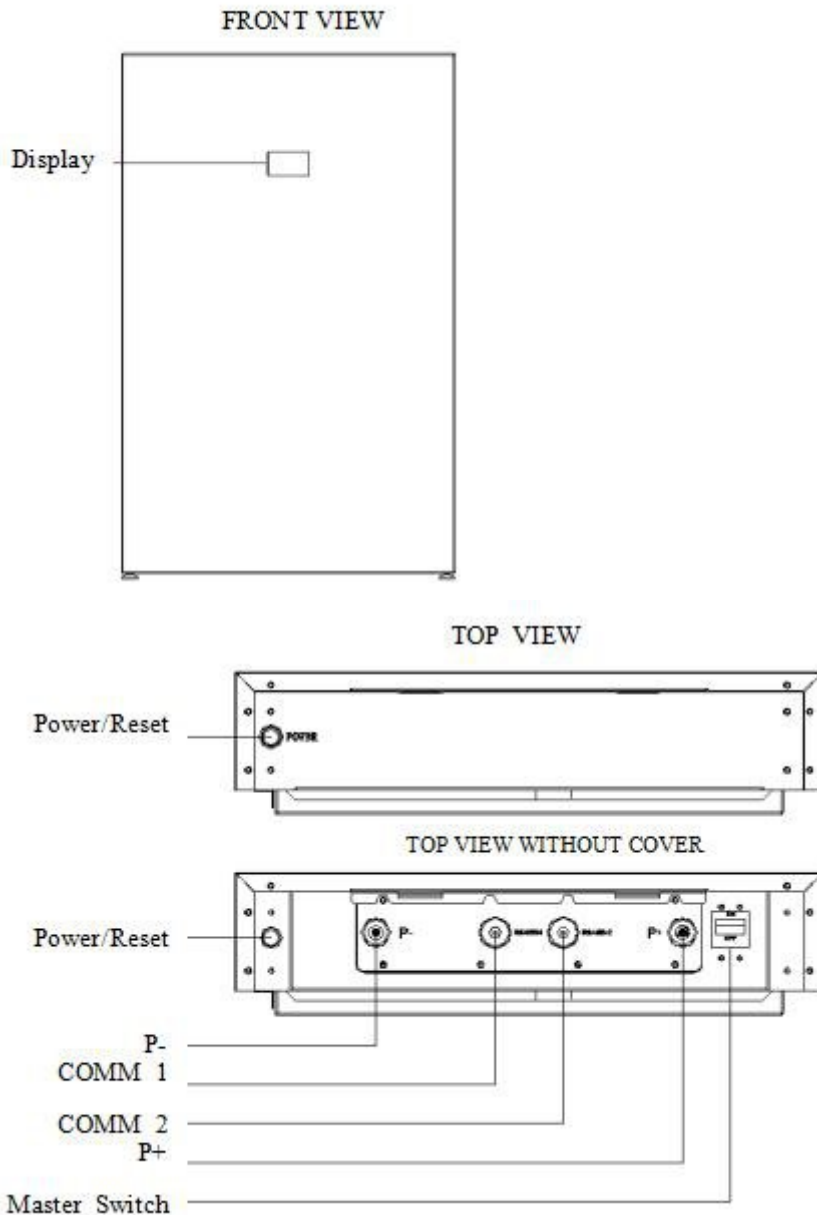

Figure 3-9

a, Display: display battery system information

b, Master switch: air switch, turn off and turn on the battery system

c. Power / Reset:

When the BMS is in sleep mode, press and hold this button for 1 second and release, the BMS is activated;

When the BMS is active, press and hold this button for 3 seconds and release, the BMS turns to sleep mode;

And, in sleep mode, the battery cannot charge or discharge.

d, COMM 1: RS485 communication interface, please contact us for protocol if the battery you order has this function.

e, COMM 2: RS232 communication interface, please contact us for protocol if the battery you order has this function.

f, P+ / P-: charge and discharge positive and negative, connect to solar inverter battery+ and battery- if working with solar inverter.

3.5 Sleep Mode

3.5.1 Enter Sleep Mode

The battery pack enters sleep mode when any of the following conditions occurs,

(1) Single cell or the whole battery pack enters over-discharge protection for 1 minute, and not recover.

(2) Press and hold the “Power / Reset” button for 3 seconds and release.

(3) The lowest single cell voltage is under preset voltage of 3300mV, and this last for a certain time of sleep delay time (default 1440 minutes), meanwhile, no communication with other devices, no charge or discharge on the battery pack.

(4) Turn off through the host computer.

Before start sleep mode, please make sure the battery pack is not under charging, otherwise, it cannot enter sleep mode.

3.5.2 Exit Sleep Mode

The battery pack exits sleep mode and back to normal working when any of the following conditions occurs,

(1) Connect the battery pack to the charger with charging voltage over 48V.

(2) Press and hold the “Power / Reset” button for 1 second and release.

(3) Connect RS485 communication, turn on the communication device.

3.6 Parallel Use

Parallel use of this battery pack is allowed.

Before the battery packs are connected in parallel, the following operations and checks must be performed.

- a. Check if the battery packs could charge and discharge normally;
- b. Check the voltage between the positive and negative terminals of the battery packs before connecting them in parallel, make sure that the battery voltage difference is within 50mV (Do NOT connect the battery packs in parallel if voltage different beyond 50mV);
- c. Turn all the power switches of the battery packs to the “OFF” state;
- d. Connect the power cables, communication cables correctly as shown in Figure 3-10 below

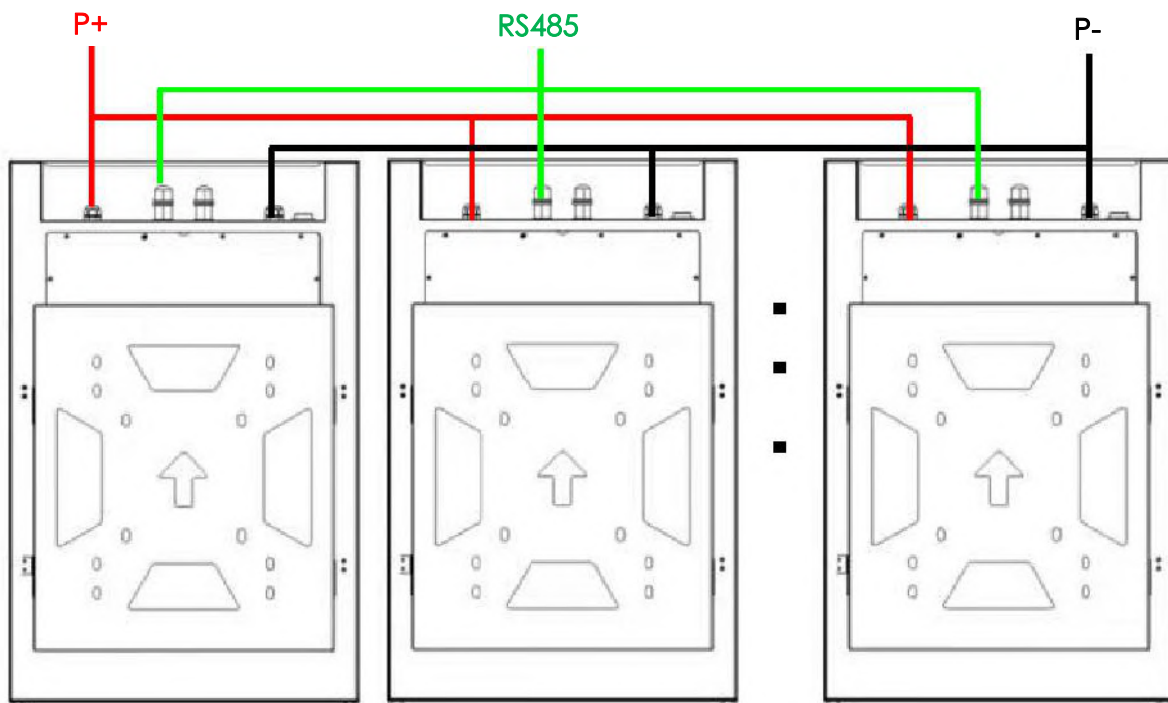

Figure 3-10

In parallel use, the RS485 interface could be connected in parallel as shown in Figure 3-11 below. The communication device could check and monitor the status, parameters and operations of all battery packs connected together in parallel.

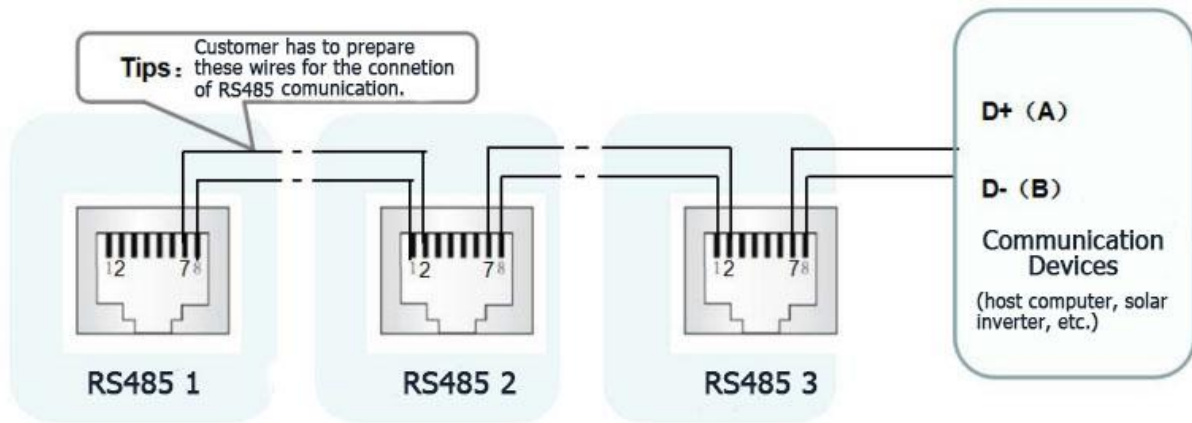

Figure 3-11



Precautions of Parallel Use

- Please connect the battery pack in parallel according to the above instructions; any operation that does not follow the instructions is prohibited.
- Do not connect the abnormal battery packs in parallel.
- Do not connect more than 7 units of the battery packs in parallel.
- Do not connect the battery packs when they are charging or discharging.
- Do not mixing connect different capacity battery packs in parallel.
- Do not mixing connect the V series battery packs with other models of batteries from Polinovel or other manufacturers.

3.7 Troubleshooting

Common Fault Analysis and Solutions as below.

Item	Fault Symptom	Solution	Remark
1. Unable to start	Press POWER button, the display does not light up.	<ol style="list-style-type: none"> 1. Check if the master switch is turned on. 2. Charge the battery pack according to the correct charging operation and observe whether the battery pack can be charged normally. 	<p>If the battery pack can be charged, it will work normally when it is charged.</p> <p>If the battery pack cannot be charged, please contact the seller.</p>
2. Unable to charge	The display works normally, but the battery pack cannot get charged.	<ol style="list-style-type: none"> 1. Check the power cord. Check if the power cord is connected properly (no reverse connection or short-circuit). 2. Check the voltage between the positive and negative terminals of the battery pack, to confirm whether the battery pack is under over-charge (high-voltage) protection. 3. Check if the charging voltage of the charger meets the battery charging requirements, and check if the charger is normal. 	<p>If the battery pack is under high voltage protection, after discharge with load devices, it can be charged again.</p> <p>If the charger doesn't meet the charging requirement of the battery pack, or charger is abnormal, please change or repair the charger.</p> <p>If the solutions in this table doesn't solve the problem, please contact the seller.</p>
3. Unable to discharge	The display works normally, but the battery pack cannot discharge.	<ol style="list-style-type: none"> 1. Check the power cord. Check if the power cord is connected properly (no reverse connection or short-circuit). 2. Disconnect the power cord between the battery pack and load, check the voltage between the positive and negative terminals of the battery pack, to confirm whether the battery pack is under over-discharge (under-voltage) protection. 	<p>If the battery pack is under over-discharge protection, please charge the battery pack before discharge.</p> <p>If the solutions in this table doesn't solve the problem, please contact the seller.</p>

Appendix:

Models and specifications of Polinovel V series solar home battery

Item	Model				
Solar Home Battery	V3000	V3000H	V5000	V7000	V8000
Nominal Capacity	60Ah	72Ah	102Ah	138Ah	162Ah
Nominal Voltage	51.2V		51.2V	51.2V	
Voltage Range	43.2-57.6V		43.2-57.6V	43.2-57.6V	
Continuous Charge & Discharge Current	100A		100A	100A	
Max. Pulse Current (for less than 1 sec)	150A		150A	150A	
Dimension	740*600*122mm		938.5*605*122mm	1235*605*122mm	
Weight	40kg	45kg	73kg	90kg	100kg
Battery Type	Lithium Iron Phosphate (LiFePO4)				
Charge Temperature	0~45℃				
Discharge Temperature	-20~60℃				
Storage Temperature	5~45℃				
BMS Protection	Over-current, over-voltage, under-voltage, short circuit, over temperature, etc				
Communication Interface	RS485				
Installation Way	Wall-mounted				